

Mega pump

- Max.vacuum level** : -92kpa (-690mmHg)
- Max.Flow rate** : 14460NI/m (867.6m³/hr)
- Supply air pressure** : 4-6bar Max. 7bar
- Supply air type** : Dry compressed air
- Working temperature** : -20°C to +80°C
- Noise level** : 68-76 dBA

Main advantages

The largest compressed air-driven vacuum pump on the market place, that is comparatively compact and light weight. This pump mainly for the application wherever larger air volume to be evacuated or to compensate for the leakage flow must remarkable application for this pump will be in conveying system for granules, transferring bulk materials and powder. This unit is complete with vacuum gauge, pressure gauge nad mechanical ON/OFF valve as standard. Air saving kit, solenoid valve, non-return valve, and with VITON® or EPDM as seal options.



Order no.

VTML200 - AS - N V

① ② ③ ④

① **Model** – Capacity equivalent to electricity motor pump size

- **VTML200** – 2KW
- VTML400 – 4KW
- VTML600 – 6KW
- VTML800 – 8KW
- VTML1000 – 10KW
- VTML1200 – 12KW

② **Air saving kit**

- No mark – Standard
- **AS** – Air saving kit attach

③ **Non return valve**

- No mark – Standard
- **N** – Non return valve

④ **Sealing**

- No mark – Standard (NBR)
- **V** – Viton®
- E** – EPDM

Characteristics

Model	max. vacuum -kPa(-mmHg)	Max. vacuum flow (NI/m)	air consumption (NI/m)	noise level (dBA)	weight (g)	min hose inner Ø (within 2m)		
						air supply	vacuum	exhaust
VTML200	92 (690)	2410	600-780	68-76	4926	>10	>32	>40
VTML400		4820	1200-1680	68-76	5116	>12	>40	>60
VTML600		7230	1800-2520	68-76	5900	>14	>50	>70
VTML800		9640	2400-3360	68-76	6700	>15	>50	>75
VTML1000		12050	3000-4140	68-76	7800	>18	>65	>90
VTML1200		14460	3600-4920	68-76	8800	>20	>75	>100

Induce air in liters per minute (NI/m)

Model \ -mmHg -kPa	0	75	150	225	300	375	450	525	600	675
	0	10	20	30	40	50	60	70	80	90
VTML200	2410	1688	1116	580	290	216	144	80	40	6.4
VTML400	4820	3376	2232	1160	580	432	288	160	80	12.8
VTML600	7230	5064	3348	1740	870	648	432	240	120	19.2
VTML800	9640	6752	4464	2320	1160	864	576	320	160	25.6
VTML1000	12050	8440	5580	2900	1450	1080	720	400	200	32
VTML1200	14460	10128	6696	3480	1740	1296	864	480	240	38.4

Time in seconds to evacuate to vacuum level (sec/l)

Model \ -mmHg -kPa	75	150	225	300	375	450	525	600	675
	10	20	30	40	50	60	70	80	90
VTML200	0,0021	0,0055	0,0124	0,029	0,054	0,09	0,153	0,274	0,67
VTML400	0,0011	0,0027	0,0062	0,014	0,027	0,045	0,076	0,137	0,335
VTML600	0,0009	0,0021	0,0047	0,011	0,021	0,034	0,057	0,103	0,252
VTML800	0,0006	0,0014	0,0031	0,007	0,014	0,023	0,038	0,068	0,168
VTML1000	0,0005	0,0012	0,0026	0,006	0,012	0,018	0,031	0,057	0,147
VTML1200	0,0004	0,0009	0,0021	0,005	0,009	0,014	0,024	0,045	0,125

Dimensional Information

VTML200 400

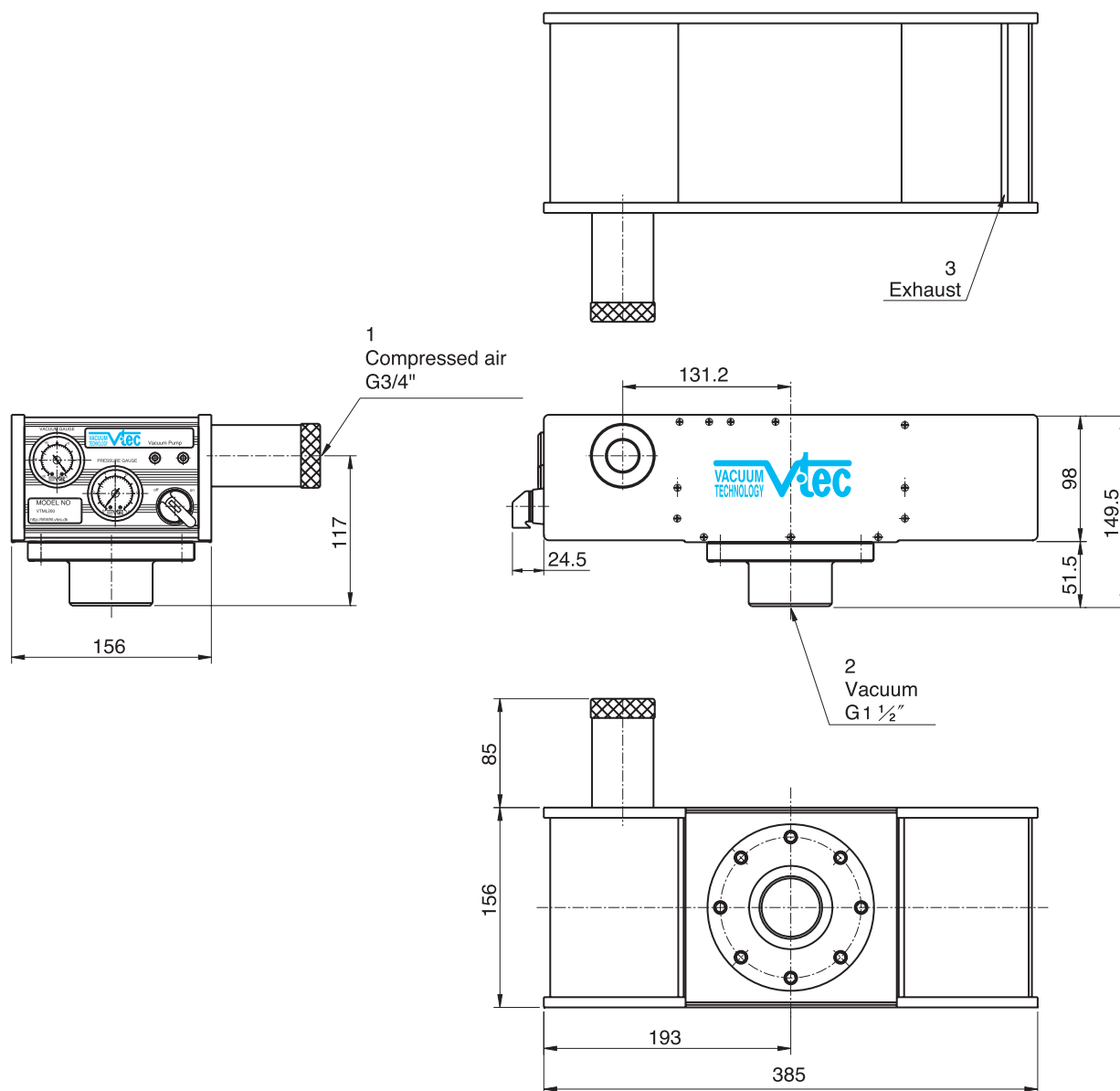

Dimensional Information

VTML600

800
1000
1200

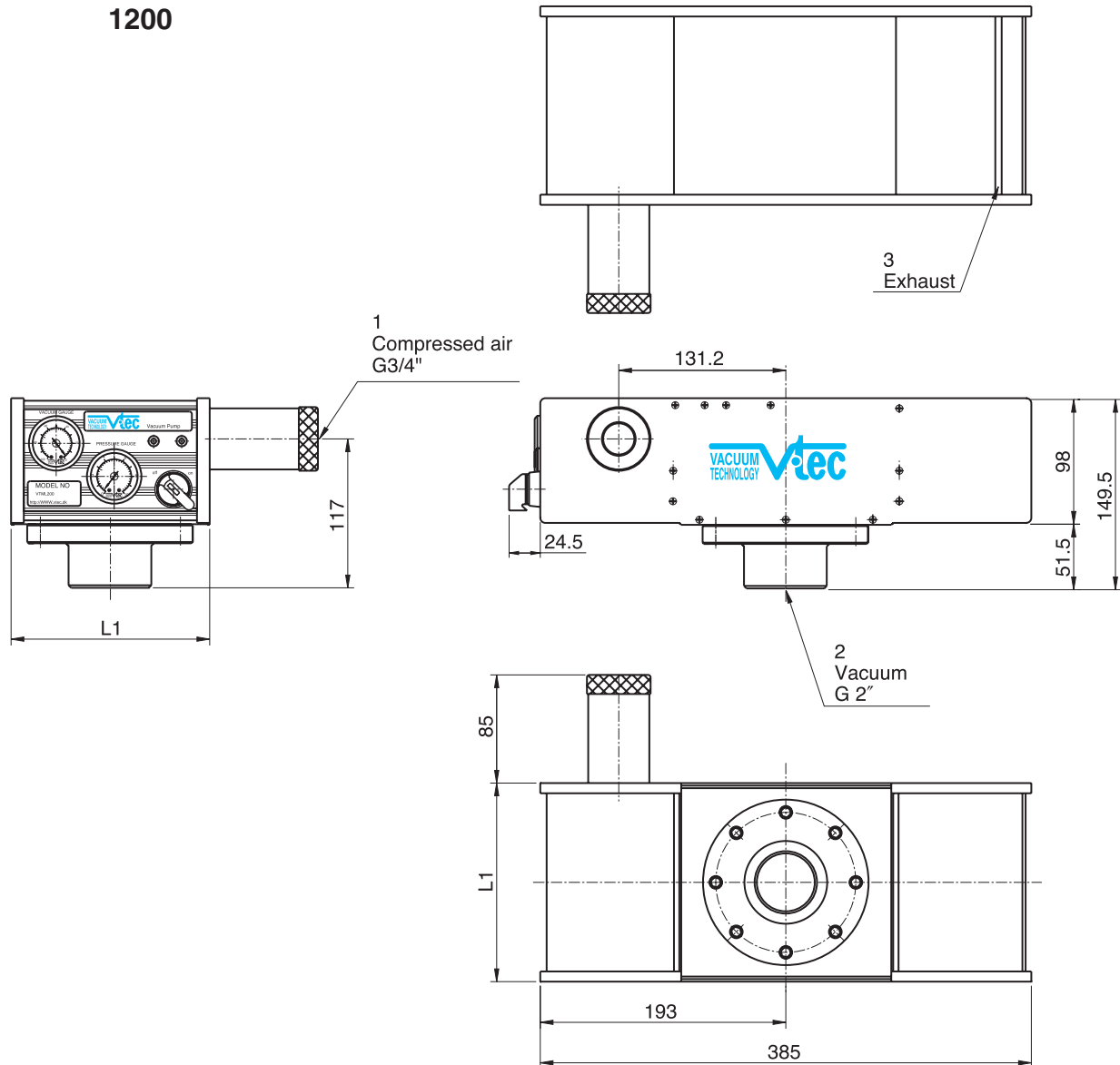

VACUUM PUMP

Model	L1 (mm)
VTML600	220
VTML800	284
VTML1000	348
VTML1200	412